

# Agilent 33304/5 Programmable Step Attenuators

Data Sheet

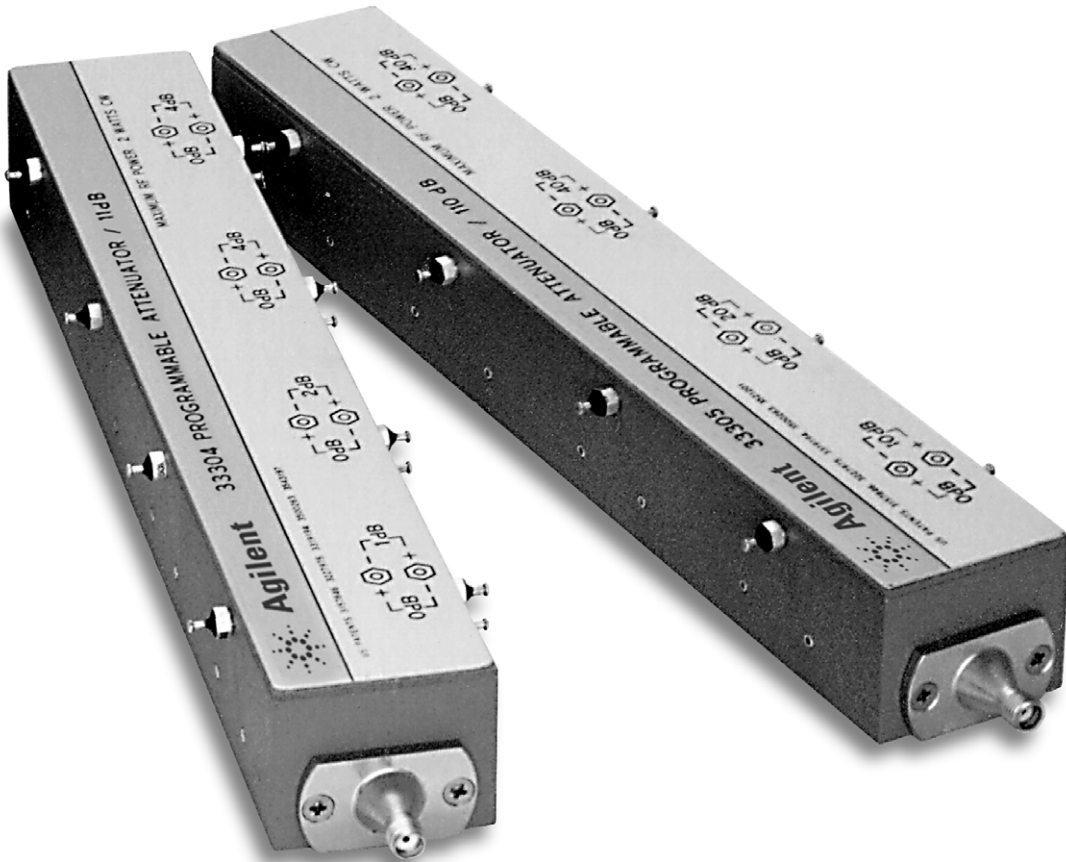

## Features and description

- Rapid switching (less than 0.05 second)
- High repeatability (0.05 dB typical)
- Broadband (DC to 18 GHz)
- Two ranges and step sizes



Agilent Technologies

## Description

The 33300 Programmable Step Attenuators provide a fast and precise means for electrically controlling the level of signal attenuation in automatic test systems, receivers, and other RF equipment. They provide attenuation up to 110 dB in 1 or 10 dB steps over a frequency range of dc to 18 GHz.

The products are defined as:

Model no.	Total attenuation dB	Step size dB
33304	11	1
33305	110	10

The 33300 series attenuators utilize a unique operating principle. Magnetic latching solenoids are used to switch individual attenuation elements (tantalum resistive films on sapphire substrates) into and out of contact with a 50-ohm transmission line. Each unit is comprised of three or four attenuation sections. By energizing the appropriate solenoid, any combination of these sections may be put across the 50-ohm transmission line to give the desired levels of attenuation.

The extreme stability of the sapphire tantalum attenuator pads, combined with the elimination of sliding contacts, gives rise to a product that has as number of important operational features. Among these are fast switching speed, excellent repeatability, compact size, long life, and high stability.

Magnetic latching solenoids move the transmission line into and out of contact with the sapphire attenuator elements. These solenoids are supplied with coils for 24-volt operation. The 24-volt coil can be run at up to 30 volts.

Because the solenoids are of the latching type, power need not be continuously maintained to keep the solenoid in either the in or the out position. It is sufficient to pulse the solenoid for 30 milliseconds at its rated voltage to change states. To change states the polarity across the terminals must be reversed. However, both terminals are "floating," so either can be grounded. Thus, unipolar power supplies are sufficient for controlling these units.

For switching speeds faster than 30 ms, this pulse voltage can be increased. A maximum of double the rated voltage may be put across the solenoids in such cases, but pulse width should be limited to keep average solenoid power below 3.3 watts per section.

Indicator contacts, which allow the user to determine whether a given section is engaged or not, can be included. These contacts are in their open position when the appropriate attenuator cards are not engaged. The contacts close, and remain closed, when the appropriate card moves into contact with the transmission line.

The 33300 series is available with any combination of 3 mm, 7 mm or Type N connectors. A three-digit code specifies these options. The first digit is always 0. The second digit calls out port 1, the third, port 2. See figure 2 for details.

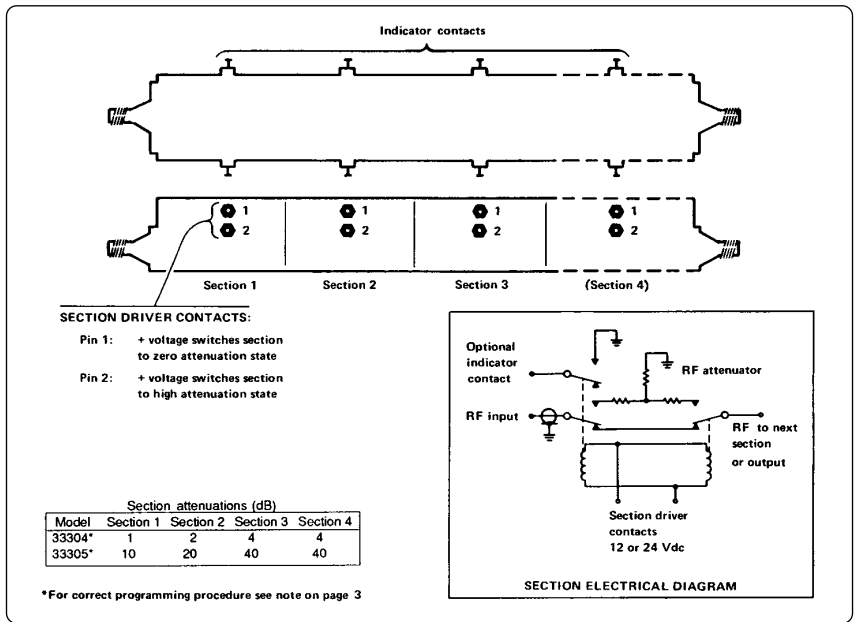

Figure 1. Electrical diagram and programming table

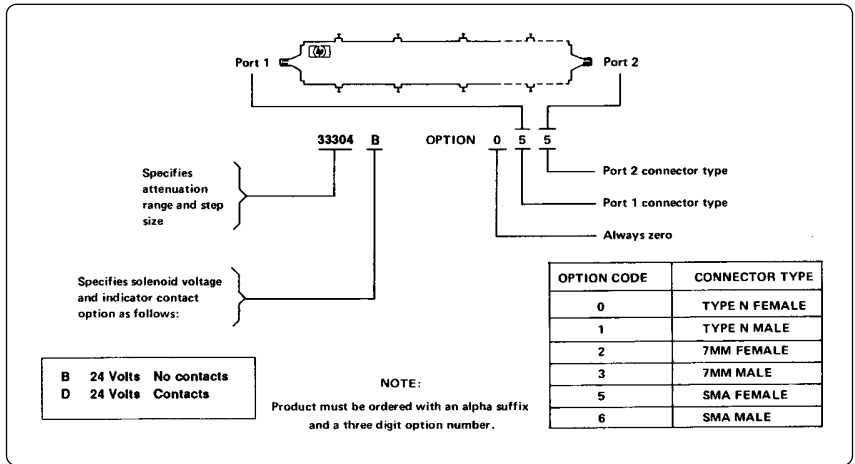

Figure 2. Ordering example

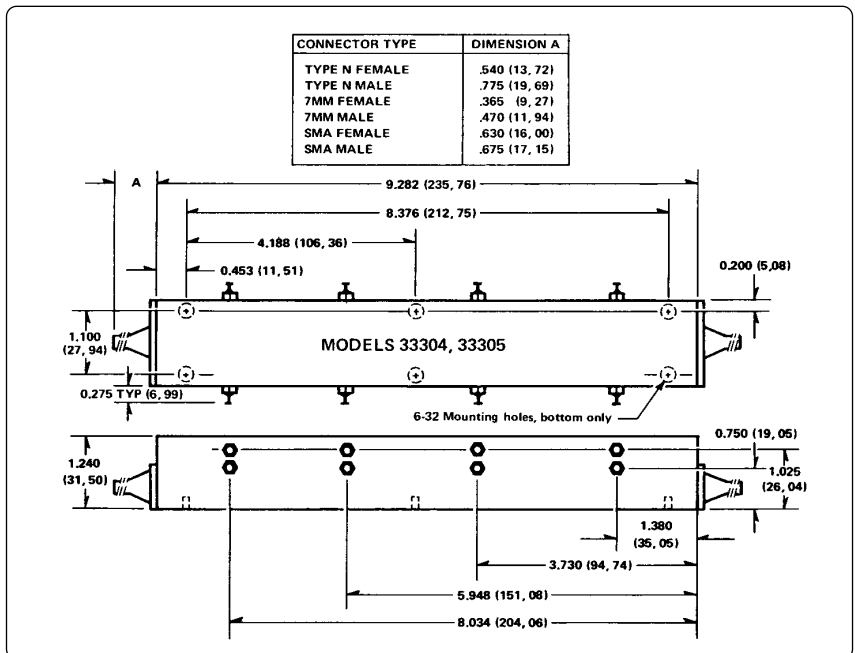

Figure 3. Outline drawings

# Specifications

## Electrical

**Frequency range:** DC-18 GHz

**Characteristic impedance:** 50 ohms

**Attenuation ranges:**

Model	Range (dB)	Step size (dB)
33304	0–11	1
33305	0–110	10

**Life, minimum:** 1,000,000 steps each section.

**Power sensitivity:** 0.001 dB/dB/ watt.

**Attenuation temperature coefficient:** Less than 0.0001 dB/dB° C

**Repeatability, typical:**

DC–12.4 GHz	0.03 dB
12.4–18 GHz	0.05 dB

**Attenuation accuracy ( $\pm$ dB) referenced from 0 dB setting:**

### 33304

DC–4 GHz	0.2	0.2	0.3	0.3	0.3	0.3	0.4	0.4	0.4	0.4	0.5
4–12.4 GHz	0.3	0.3	0.4	0.4	0.4	0.4	0.5	0.5	0.5	0.5	0.6
12.4–18 GHz	0.5	0.5	0.6	0.6	0.7	0.8	0.8	0.8	0.8	0.8	0.9

### 33305

Frequency range	Attenuator setting (dB)										
DC–12.4 GHz	0.5	0.7	0.9	1.2	1.5	1.8	2.1	2.4	2.7	3.0	3.3
12.4–18 GHz	0.6	0.8	1.2	1.6	2.0	2.4	2.8	3.2	3.6	4.0	4.4

Note: The attenuation sections 3 and 4 of both the 33304 and 33305 have equal attenuation values. There are attenuator configurations which require only one of those to be activated. The above accuracy specifications are guaranteed only when section 3 is used in preference to section 4.

### VSWR: 33304 and 33305

Frequency range	Connector type		
	SMA	Type N	7 mm
DC–8 GHz	1.5	1.45	1.4
8–12.4 GHz	1.6	1.55	1.5
12.4–18 GHz	1.9	1.8	1.7

**Solenoid voltage and nominal coil impedance:**

Models	Solenoid voltage	Coil impedance
33304B/D	24 to 30 Vdc	262 ohms
33305B/D		0.192 ohms

**Power required to switch one section:** 3.3 watts.

(Continuous operation of solenoids requires 10 watts dissipation in heat sink.)

## Environmental

**Temperature, non-operating:** –40° C to +85° C.

**Temperature, operating:** –20° C to 55° C.

**Altitude, operating:** 25,000 ft.

**Vibration, operating:** 5 – 500 – 5 Hz, 15 min./cycle, 3 hours/axis. 0.100-inch D.A. to 31 Hz, 5 g's to 500 Hz, with and without power applied to the relays in both positions.

## Ordering information

See figure 2 for ordering information.

## Agilent Technologies' Test and Measurement Support, Services, and Assistance

Agilent Technologies aims to maximize the value you receive, while minimizing your risk and problems. We strive to ensure that you get the test and measurement capabilities you paid for and obtain the support you need. Our extensive support resources and services can help you choose the right Agilent products for your applications and apply them successfully. Every instrument and system we sell has a global warranty. Support is available for at least five years beyond the production life of the product. Two concepts underlie Agilent's overall support policy: "Our Promise" and "Your Advantage."

### Our Promise

Our Promise means your Agilent test and measurement equipment will meet its advertised performance and functionality. When you are choosing new equipment, we will help you with product information, including realistic performance specifications and practical recommendations from experienced test engineers. When you use Agilent equipment, we can verify that it works properly, help with product operation, and provide basic measurement assistance for the use of specified capabilities, at no extra cost upon request. Many self-help tools are available.

### Your Advantage

Your Advantage means that Agilent offers a wide range of additional expert test and measurement services, which you can purchase according to your unique technical and business needs. Solve problems efficiently and gain a competitive edge by contracting with us for calibration, extra-cost upgrades, out-of-warranty repairs, and on-site education and training, as well as design, system integration, project management, and other professional engineering services. Experienced Agilent engineers and technicians worldwide can help you maximize your productivity, optimize the return on investment of your Agilent instruments and systems, and obtain dependable measurement accuracy for the life of those products.

**By internet, phone, or fax, get assistance with all your test and measurement needs**

**Online assistance:**

**[www.agilent.com/find/assist](http://www.agilent.com/find/assist)**

**Product specifications and descriptions in this document subject to change without notice.**

© Agilent Technologies, Inc. 2001  
Printed in USA, August 8, 2001  
5953-2354



**Agilent Technologies**